

GLOBAL ACADEMIC RESEARCH INSTITUTE

COLOMBO, SRI LANKA



GARI International Journal of Multidisciplinary Research

ISSN 2659-2193

Volume: 01 | Issue: 02

On 31st December 2015

<http://www.research.lk>

Author: W. A. D. N. Gunatilake, B. G. H. M. M. B. Herath, B. G. C. T. Bowatta,

Dr. N. D. Jayaweera, Mr. C. M. S. P. De Silva

Department of Mechanical Engineering, University of Moratuwa, Sri Lanka

GARI Publisher | Engineering | Volume: 01 | Issue: 02

Article ID: IN/GARI/02ICET/2015/101 | Pages: 46-62 (17)

ISSN 2659-2193 | Edit: GARI Editorial Team

Received: 15.10.2015 | Publish: 31.12.2015



DESIGN AND DEVELOPMENT OF KINETIC ENERGY RECOVERY SYSTEM FOR
MOTOR VEHICLES

¹ W. A. D. N. Gunatilake , ² B. G. H. M. M. B. Herath , ³ B. G. C. T. Bowatta , ⁴ Dr.
N. D. Jayaweera , ⁵ Mr. C. M. S. P. De Silva

^{1,2,3,4,5} Department of Mechanical Engineering, University of Moratuwa, Sri Lanka

¹ dnishadika@gmail.com

ABSTRACT

Invention of the internal combustion (IC) engine is a huge forward step in automobile industry. However its inefficiencies and mass production caused depletion of crude oil and many environmental threats. In order to avoid these, researchers and engineers have been working on various methods to improve the fuel efficiency of automobiles through the analysis of waste energy recovery. Among them, methods of recovering kinetic energy have significant impact on improving the fuel efficiency. Today, both electric and hybrid vehicle are embedded with the kinetic energy recovery systems, but the reduced life cycles, disposal hazards, huge weight and high cost of batteries made them to drain their popularity. These make conventional vehicles to represent the majority of the transportation even if they have no such method of energy recovery. In that case, it is worth to research on other methods of kinetic energy harvesting and storage which are applicable for the conventional vehicles too. Compared to batteries, flywheel is a reliable and cost efficient energy storage which has lesser initial cost, maintenance and environmental impact. Continuously variable transmission (CVT) and motor generators system are already using flywheels but have controlling difficulties, design complexities and inefficiencies due to gear reduction. This is about a novel mechanism to harvest waste kinetic energy during braking. It will replace the drawbacks of existing flywheel energy recovery systems. The model consists of springs to temporary store recovered energy and feed to flywheel with energy storing efficiency of 36%. An optimized model will give a higher value. Keywords: Fuel efficiency, Kinetic energy recovery system, Flywheel



INTRODUCTION

IC engines brought a new era for automobile industry. Still most of the vehicles on roads are powered by IC engines. Even though the fast depletion of crude oil and escalating environmental pollution draw the attention of the people towards IC engines in a different angle, still there is no proper invention done to replace the IC engines. However, optimization of fuel efficiency is found as a partial solution to crude oil scarcity.

Hybrid and electric vehicles are playing a vital role in energy crisis with the recent development of battery technologies. Considering the amount of energy waste and recovering possibilities, kinetic energy recovering methods have a significant impact on improving the fuel efficiency. Prior to the development of electric battery, kinetic energy recovering methods were not used because of the energy storage difficulties. Even though hybrid and electric vehicles are emerging faster today, still there are billions of conventional vehicles and they will be running for another few decades. The point is, they have no any energy recovering methods as hybrid or electric vehicles, and yet it is also not practical to fully convert their power trains into hybrids. An energy recovery device with a tangible energy storage, which requires no complex installation, could be a possible solution.

Speaking of energy storages for automobiles, electric battery and fly wheel are the most widely used energy storages (Dhand and Pullen, 2015). When it is considered the initial cost, maintenance, efficiency and environmental issues, fly wheel energy recovery systems seem practical for both electric and conventional vehicles. Rotational kinetic energy of a flywheel is directly proportional to the mass of the fly wheel, and square of angular velocity. When a vehicle is moving with a varying speed, it is difficult to harvest energy and energize the flywheel because vehicle speed and fly wheel rotating speed are independent. This is a critical problem attached to fly wheel based energy recovery systems in automobiles.

Existing fly wheel energy storage systems for automobiles generally consist of two methods. One method is rotating a motor generator by engaging it with the vehicle wheel and use that generated electrical energy to rotate another motor generator which is connected with a fly wheel. This method is inefficient because there are several energy conversion steps involved. The other method is using CVT with several gear reductions and clutches. Cost of manufacturing this type of system is too high and controlling of CVT is difficult. Considering all these limitations and emphasizing the importance of energy saving, this project introduces a novel concept of harvesting waste kinetic energy from automobiles. Since it uses a flywheel to store the harvested energy, the device is more reliable, has less manufacturing cost and easily maintainable than existing methods.

LITERATURE REVIEW

There are many literatures regarding energy harvesting in a variety of situations using different types of devices and mechanisms. Since this project is focused on kinetic energy recovery from motor vehicles, this paper only presents the relevant literature reviewed over a narrowed down area.

Types of kinetic energy waste in automobiles

There are several ways a vehicle losses kinetic energy when it is moving. Researchers and engineers have done a lot of research about vehicle kinetic energy wasting and still they are looking for better solutions to reduce that as much as possible. The list below contains the situations where a vehicle lose its kinetic energy by a significant amount.

- During braking
- In suspension system
- Aerodynamic drag force
- Rolling resistance

Kinetic energy waste during braking

Braking always ends up with a large amount of kinetic energy loss. In conventional vehicles, application of brakes is to reduce the vehicle speed or to stop its movement. In braking systems of conventional vehicles, friction is used as the reaction force which reduces the forward momentum of the vehicle. This process converts vehicle kinetic energy in to heat. Generated heat is carried away by the air stream and the kinetic energy of the vehicle is successfully wasted. Amount of kinetic energy wasted depends on how hard and how long the brakes are applied.

Vehicles which are driven city centered, involve more braking events representing a much higher kinetic energy loss with a greater potential energy savings. When a vehicle is driving in heavy traffic, more than half of the total energy is dissipated in the brakes (Wong, 2008). This is a remarkable turning point that researchers have identified. Vehicle weight and travelling speed also have a direct impact on kinetic energy wasting during braking (Clegg, 1996). Mathematical equation of kinetic energy of a moving motor vehicle with mass (m) and velocity (v), kinetic energy (E) is expressed by the equation (1) (Wong, 2008).

$$E = \frac{1}{2}mv^2$$

According to this equation, if the speed of a vehicle is doubled, it has four times as much energy. In that case, the brakes must dissipate four times as much energy to stop it and consequently the braking distance is also increasing four times.

Regenerative braking is a great approach that researchers have found to recover waste kinetic energy during braking. If energy wasted during braking is regenerated with no losses in a regenerative system, fuel consumption might be improved by 33%. In practical case, regenerative braking approaches to extend the driving range of electric and hybrid vehicles and it can save from 8% to 25% of the total energy used by the vehicle, depending on the driving cycle and how it is driven. Research by Volkswagen company has shown

that a hybrid drive with both electric drive and internal combustion engine offers potential fuel saving of over 20% compared with just 5-6% from purely electric (Gantt, 2011). VOLVO Company’s ongoing work with energy harvesting by regenerative braking for city buses has reached the stage where two prototype passenger vehicles with flywheel and alternative hydraulic accumulators are in trial route service in Stockholm. Recycling power in this way gives fuel savings of up to 30% in the regular stop start driving of urban bus operation. The drive concepts have been developed by company name as ‘Volvo fly motor’ (Arthor, 2013).

Kinetic energy waste in suspension system

Suspension is another scenario that a vehicle loses its kinetic energy. The function of the vehicle suspension system is to reduce the vehicle chassis disturbances from the road, enable wheels to contact with the road as much as possible and ensure the ride comfort. This system usually consists of a spring and a damper, as shown in Figure 1. Damper absorbs the vibration caused by the vehicle moving on irregular road surfaces and dissipate that vibration energy as heat energy. However, this dissipated heat energy originally is from the fuel in conventional vehicle or from the battery, if it is an electrical vehicle.

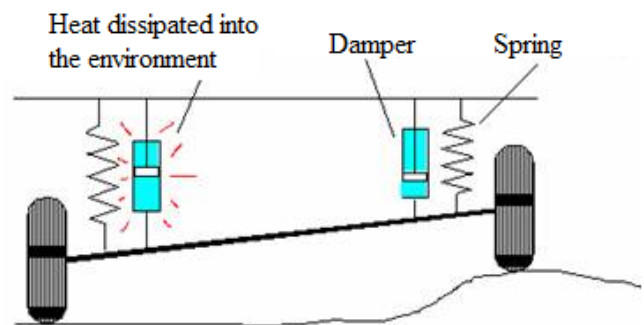

Figure 1 – Heat dissipation in suspension system (Courtney and Klee, n.d)

The amount of kinetic energy dissipation in suspension system is related with road roughness, vehicle speed, suspension stiffness and damping coefficient. Analysed data over energy dissipation of dampers in a passenger

vehicle is about 200W when it is running on poor road conditions at a speed of 13.4 m/s. Theoretical results show that a maximum of 10% fuel efficiency can be gained from vehicle suspension system by implementing regenerative shock absorbers (Knowles, 2011).

Zuo and Zhang (Zuo and Zhang, 2013) assessed the energy potential of vehicle suspension systems through an integrated mathematical modelling of ‘road vehicle harvester system’, which was verified by road tests. In this model, the excitation from road irregularity is modelled as a stationary random process. The conclusion is that for a middle-sized passenger car with four shock absorbers, average powers of 100, 400, and 1600 W are available for harvesting while driving 96.5 km/h on Class B, Class C, and Class D roads, respectively. These classes are categorized according to their conditions such that class B represents good conditioned roads while class C and D represent average and poor road conditions respectively. The theoretical modelling is validated by road test using a super compact vehicle.

Assuming 75% energy harvesting efficiency, the regenerative shock absorbers of a middle-sized passenger car can recover 300W electricity on class C road at 96.5 km/h (Zuo and Zhang, 2013). As noted in a general motors article, the typical electricity usage of a vehicle is about 250–350 W with all optional systems turned off, which is currently generated by the alternator driven by the engine crank shaft. In that case, A 300 W of electricity must not be underestimated. The alternator has a typical power capacity of 500–600 W and an efficiency of 55% (Murchison, 2011). Considering the efficiency of engines and alternators, 300 W of electrical power means about 1800 W of petroleum fuel power. According to amount of energy wasting on the suspension system and inefficiency of the internal combustion engine, kinetic energy waste in a vehicle suspension system is not negligible.

Kinetic energy waste due to aerodynamic drag force

In the presence of resistant forces, vehicle requires excess energy in order to maintain its forward motion. This happens when the aerodynamic forces from the surrounding air are acting on the vehicle body. Figure 2 indicates the types of aerodynamic forces acting on a moving vehicle and the directions relative to the direction of vehicle.

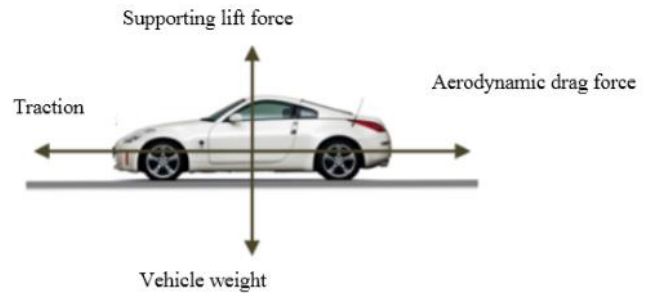

Figure 2 – Forces acting on a moving vehicle (Himme and O’Hanlon, n.d)

Aerodynamic drag consists of two main components as skin friction drag and pressure drag. Pressure drag accounts for more than 80% of the total drag and is highly dependent on the vehicle geometry due to boundary layer separation from rear window surface and formation of wake region behind the vehicle. This is one of the major factors that decrease fuel economy in automobiles, because it significantly affects on the vehicle kinetic energy. The aerodynamic drags of a road vehicle is therefore responsible for the high fuel consumption of the vehicle. This builds further up to 50% of the total vehicle fuel consumption at highway speeds (Khalighi at el., 2012)

Rohatgi (Rohatgi, 2012) tested a small scale model of General Motor SUV, which is 1710 mm in length, in the wind tunnel under expected road clearance and wind conditions for two passive devices. the car’s shape is converted into a specific shape such that the end of the car is aerodynamically extended. It is found that the rear screen of the model is capable of reducing the drag up to 6.5% and rear fairing can reduce the drag by 26%. However, due to the aesthetic and practical considerations of vehicle the implementation of any drag reduction options was limited.

Sharma and Bansal (Sharma and Bansal, 2013) studied the variation drag coefficient of a passenger car with a modification added as in figure 3. The results showed that the tail plates contribute to reduce lift coefficient by 16.62% and the drag coefficient by 3.87% in head-on wind. They concluded their study stating that the drag force can be reduced by using add on devices on vehicle. It leads to improve not only the fuel economy but also the stability of the passenger car.

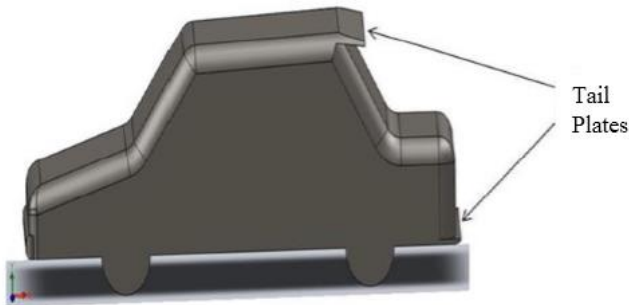

Figure 3 – Passenger car with tail plates (Sharma et al., 2013)

Reducing the aerodynamic drag provides an inexpensive solution to improve fuel efficiency. Thus, the shape optimisation for low drag becomes an essential part of the overall vehicle design process. It is found that 40% of the drag force is concentrated at the rear of the geometry. When considering the effect of the aerodynamic drag force on automobiles it is necessary to reduce it in order to improve the fuel economy by reducing the amount of waste kinetic energy.

Kinetic energy waste due to rolling resistance

Conducting research on vehicle tires is extremely important because tire is the part that connects the vehicle and the ground. Further, it provides cushioning, dampening and assure good directional stability. There are lot of research carried out on tires, because it is responsible for about 20-30% of total fuel consumption of the vehicle (Miège and Popov, 2005). That explains the necessity of researching tires to minimize kinetic energy waste. Vehicle tires are made from rubber which is a viscoelastic material. The loading and unloading stiffness curves of these materials are not exactly the

same. When the tire rotates, it is subjected to a repeated cycle of loading and unloading. This causes the elastic hysteresis of tire material. Under this condition tire losses kinetic energy in the form of heat. The amount of kinetic energy waste depends on the mechanical characteristics of the tire. Most importantly, hysteresis energy loss in rubber tends to decrease when the temperature is increasing (Hunt et al., 1997).

The effects of tire rolling resistance on automobile fuel efficiency were evaluated by installing fifteen different tire models on a new 2008 Chevrolet Impala LS using the 2008 five driving cycle of Environmental Protection Agency (EPA) fuel economy test. This procedure measures fuel consumption under simulated conditions of city and highway driving, and adds a highway driving cycle which includes higher speeds and harder acceleration, a city cycle with air conditioning use, and a city cycle at -7°C conditions. Testing was completed under contract by the Transportation Research Centre Inc.'s emissions laboratory. Analysing the results based on five different fuel economy cycles, a 10% decrease in tire rolling resistance resulted in an approximately 1.3% increase in fuel economy for the vehicle (Epa.gov, 2014).

Kinetic energy waste in road speed breakers

The number of vehicles passing over a speed breaker on the road is increasing day by day. Vehicles have different weights depending on their nature. Trucks, lorries and busses have considerably large weight compared with cars, three wheelers and motor bicycles. When a heavy vehicle is passing over a speed breaker, a lot of energy is wasted. Setting up an energy harvesting device beneath speed breaker, might help conserving this energy and use it for useful work such as street lighting, traffic lighting, in nearby areas. This is an effective way to support the country's economy. VIT University in India have done a project on harvesting energy using the above method (Bhagdikar et al., 2014). When a vehicle reached to a speed breaker, it spins the rollers which connects with a generator. Ultimately, the wasting kinetic energy is converted into electricity. Another similar method uses the force acting on the

speed breaker directly to push a piston or spring mechanism. That action creates a water flow which is initially stored in a water tank beneath the speed breaker. This water flows through a rotor blade which rotates and the generator.

State of art of kinetic energy recovery systems in automobiles

The basic principles of physics states that the energy can neither be created nor destroyed but it can be endlessly converted. Each type of kinetic energy recovery system is built up on the same principle. They only differs from each other depending on the form of recovered energy, the energy storage and the energy converting mechanism of the system. Related literature emphasizes that the major kinetic energy losses in a vehicle occurs at the vehicle brakes and the suspension system. With developing road systems, the surface irregularities are fading off minimizing the window for suspension. On the other hand, day by day the number of vehicles emerging on the roads is rapidly increasing making the city driving almost impossible without traffic. This opens a huge window for automobiles to waste a large amount of kinetic energy at the brakes. Holding on to that thought this section of the literature review is focused on the existing regenerative braking systems.

Use of flywheel over battery as energystorage inRBS

Both the hybrid and electric vehicles nowadays are using rechargeable direct current Li-Ion batteries as the energy storage of the RBS. In those vehicles, the power train is embedded with three phase electric motor/generator configuration in order to achieve high driving torques. Once the brake applied, the kinetic energy is converting to an alternative electric current by the generators attached to the wheels of the vehicle. Then it goes through a rectifier and/or inverter converting it to DC power and stores in the battery. Some systems use brushless DC motors in order to eliminate the rectifier device from the power train to enhance the simplicity of the system (Ajmal and Ramachandramoorthy, 2015). The reuse of the stored energy is following the same path in the opposite

direction. However, when the number of loading and unloading cycles is increased the durability of batteries will reduce. When a vehicle is taking a sudden acceleration the batteries going to discharge rapidly. This kind of rapid discharges will damage the battery and the life time of the batteries will be reduced. To overcome those disadvantages it has been introduced super capacitors as electrical energy storages. Super capacitors are based on carbon nanotube technology and they can store a very large energy, can discharge large amount of electric energy within a small time period and have long life time. The super capacitors are used with batteries in modern electric RBS in order to increase the battery life (Fujimoto, 2010).

Flywheels have completely different characteristics as energy storages compare with batteries. Batteries stores electricity in the form of chemical energy while flywheels stores energy in the form of rotational kinetic energy (RKE). Since the renewable energy systems require rechargeable energy storage devices, here the focus is on to the rechargeable batteries. Energy storage capacity of electric batteries can have values up to 10 MW but the discharge time at rated power takes minutes. On the other hand, flywheels have a lesser storage capacity up to 1 MW when operating within the safe range, but the discharge time at rated power takes few seconds (Vazquez et al., 2010). This property itself is qualifying for the ultimate purpose of RBSs to respond quickly. Most importantly, flywheels are made of eco-friendly materials while the batteries contain highly toxic matter.

Equation (2) represents the amount of RKE a flywheel can store in terms of the flywheel inertia (I) and its angular velocity (ω). According to that, theoretically flywheel based energy storing systems can achieve unlimited energy capacity because the angular velocity of the flywheel has no limitation. Modern flywheel systems are capable of rotating at 16,000 rpm. However the angular velocity can be increased up to 60,000 rpm with satisfying safety regulations. However, with extremely protective environment, flywheels can have very large storage capacity (Luo et al., 2015).

$$RKE = \frac{1}{2} I\omega^2$$

Existing flywheel based energy storing RBS

In flywheel base regenerative braking systems, the kinetic energy of the moving vehicle is transferred from wheels to the flywheel while braking. That increases flywheel speed while reducing speed of the vehicle's wheels. The ratio between flywheel and vehicle wheel is continuously varying with time. In that case fixed transmission systems cannot be used to drive the flywheel. In order to overcome this problem, the following methods are used in regenerative braking systems (Dunne and Ponce, 2015).

Flywheel is mechanically driven through Continuous Variable Transmission (CVT) unit.

Flywheel is electrically driven via electrical motor/generator unit.

Flywheel based RBS using a CVT

The CVT unit is placed between flywheel and vehicle's wheels or vehicle's propeller drive shaft in the powertrain of the RBS. CVT unit allows to transmit power from vehicle's wheels or propeller drive shaft to fly wheel continuously. When it needs to reuse the stored energy it can be used a CVT unit to transmit energy from flywheel to the vehicle wheels. There is an existing flywheel based CVT RBS developed by VOLVO Company. This system is consisted of a CVT module, an output gear train, a hydraulic manifold and a flywheel module with maximum speed of 60,000 rpm.

The CVT unit in here is operated by electronically controlled hydraulic power system. The overall CVT system is very complex and expensive in manufacturing and maintaining (Dhand and Pullen, 2014). In that case, though the CVT system solved the main problem with flywheel base RBS, it is not practicable for commercial automobile market, because the customers are usually looking for simple and low cost products.

Flywheel based RBS using electrical motor/generator unit

This is a system that replaces the CVT unites by an electrical motor/generator unit. This method is mostly used in formula one racing cars. Here, the kinetic energy of the vehicle is converted to electrical power using a generator while braking. The generated power is fed to the flywheel by an electric motor. The revers power is also flew through this powertrain. In this mechanism, the electric motor acts as an electric generator and the generator acts as an electric motor. Though this system avoids complex CVT unit, it involves too many steps of energy conversion leading to a higher energy losses during transmission. . Furthermore, these systems are controlled by complex and expensive power electronics systems and therefore not commercially available. The mass to power ratio of the systems are also considerably high.

METHODOLOGY

Based on the literature review, discuss the possibilities of kinetic energy harvesting from motor vehicles while using flywheel as an energy storage.

Discuss about the conceptual mechanisms which can be useful in model designing to validate the novel concept of kinetic energy harvesting.

Select the most efficient and reliable mechanism and design a 3D model of it with the aid of a CAD software.

Check for stress simulations and do the needful modifications to the 3D model.

Calculate the percentage of theoretically harvestable energy using the suggested mechanism by means of a mathematical model.

Fabricate a prototype of the 3D model and obtain the percentage of practically harvestable energy.

Compare the variations of practical results from theoretical results.

Discuss the suggestions for improvement.

Primary stage prototype

The objective of the primary stage prototype is to check whether the conceptual mechanism is working or not. The simulation of spring actions by computer aided software is complex, therefore the prototype is expected to give the required data. Primary stage prototype in Figure 4 consists of a spring to store energy temporarily, a cam plate, linear guide, a rack and pinion, a one-way clutch, a flywheel and a structure to support all these components. The one-way clutch is used to compress and release the spring, while the flywheel which is attached to it stores energy. First a rack and pinion system was developed with one way rotating pinion. Here, a bicycle freewheel is used as the one-way rotating pinion and a bicycle chain as the rack. The linear guide is fabricated using an aluminum box bar and rollers to experience lesser friction during the sliding. The special shape of the cam guides the spring to a gradual compression and then a sudden expansion feeding the temporarily stored energy to the flywheel.

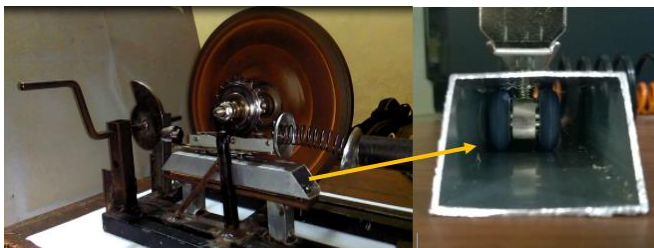

Figure 4 – Primary stage prototype with single snail cam

The conceptual mechanism worked perfectly as expected even though it had a few limitations. The maximum speed of the flywheel is not large enough due to the mechanical power loss of the power train and also there is no any gear reduction in the system. Another significant short coming is the unbalance of the flywheel. The force expected to be experienced by the slider is only in the direction of the movement of the slider. Since the cam shape is complex, practically the slider is experiencing many forces in other directions as well and there for the direction of the resultant force is undesirable. In that case, the analysis of the free body

diagram of the prototype is complex. On the other hand, when the prototype is in action, the slider is trying to pull up and push aside due to that forces. Due to the unstable spring placement, the spring seemed to be bent during the compression.

Secondary stage prototype

The primary stage prototype is used to design and to develop the secondary stage prototype. When selecting a suitable mechanism, many alternatives are considered such as energy transferring through planetary gear system, quick return mechanism, spring, sector gear and barrel cam integrated mechanism and spring, sector gear and snail cam mechanism. Compared to the others, the latter is considered simple, compact and possible to manufacture easily. The energy transfer from automobile wheel to the storage and the way back to the automobile wheel can easily done using the same mechanism. Figure 5 shows the designed 3D model (a) and the actually fabricated prototype (b).

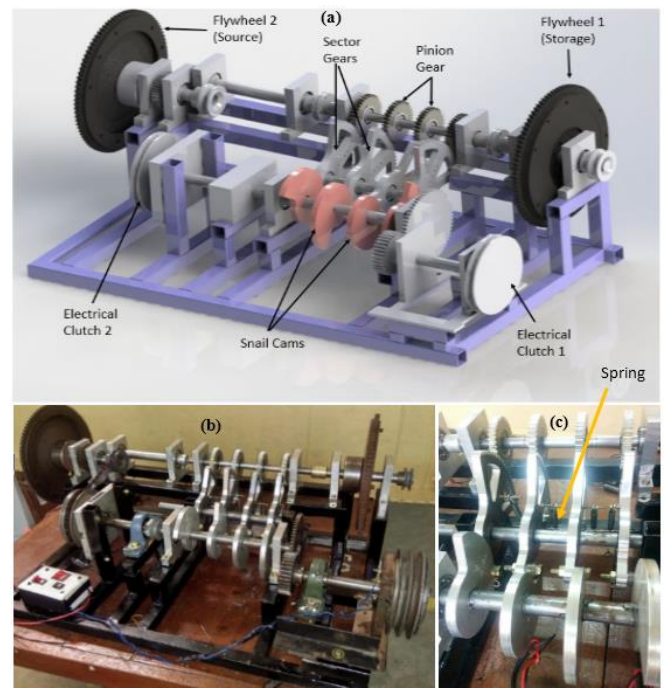

Figure 5 – Secondary stage prototype and 3D model

The pinion gears are on one-way ratchet bearings. This allows the energy storage flywheel to rotate without any disturbances from the opposed torques on sector gears.

Flywheel 2 represents the inertia of the vehicle wheel. There are four snail cams in the prototype which are in a 90° of angular offset from each other.

Sector gears can freely rotate about their axis which is rigidly fixed to the structure. However at a specific point on the symmetrical line of the sector gear, one end of the spring is connected as shown in Figure 5(c). The other end of the spring is attached to the structure. The modules of sector gears and pinion gears are equal.

Rotational speeds of the flywheels are independent of each other even though one is supplying energy to the other. Material used for shafts, snail cams, sector gears and pinion gears is aluminum while both flywheels are made of cast iron.

Power transmission paths of the developed mechanism are shown in Figure 6. In the Braking Mode, once brake is applied, the clutch 2 engages and the coupling 1 is engaged. In the Assistive Mode, once the accelerator pedal is pushed, the clutch 1 and coupling 2 engages transferring energy from the flywheel to the vehicle.

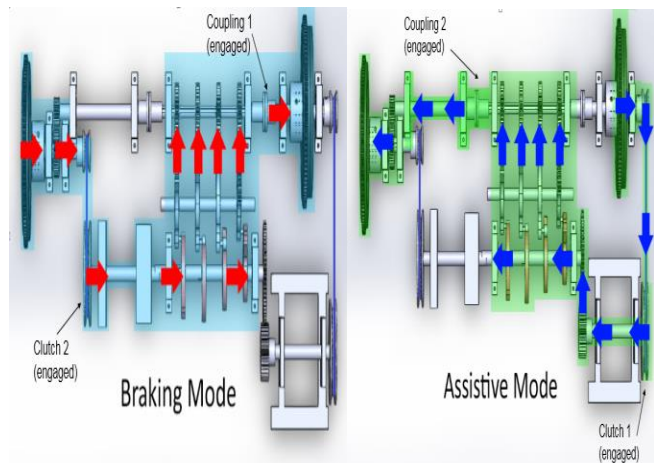
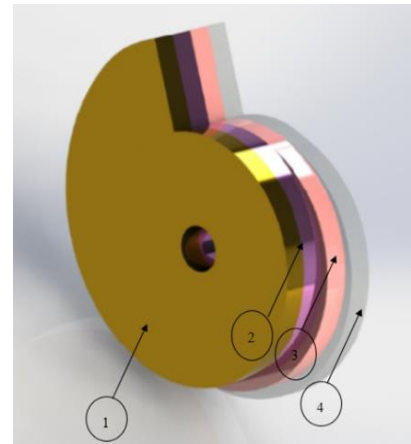

Figure 6 – Power transmission paths

The profile of the cam is playing a major role in this device. Four different cams which had four separate cam profiles as shown in figure 7 are tested in order to identify a suitable shape for the cam to be used in the actual device. For the fabricated prototype, cam 3 is selected because it has a higher increasing rate of radius at the beginning and a very low increasing rate of radius

at the end. This behavior ensures the smoothness of supplying tension force to the spring. Table 1 shows the respective cam design equations.



- 1- Cam profile 1
- 2- Cam profile 2
- 3- Cam profile 3
- 4- Cam profile 4

Table 1 – Selected cam profile equation

Cam profile no.	Cam Profile Equation
3	$X_{\alpha} = \left(0.05 + \frac{0.12\alpha}{5\pi}\right) \sin(\alpha)$ $Y_{\alpha} = \left(0.05 + \frac{0.12\alpha}{5\pi}\right) \cos(\alpha)$ <p style="text-align: center;">where $0 < \alpha < 5\pi/3$</p>

MATHEMATICAL MODEL

According to the final design, a mathematical model is built based on the geometrical relationship between the snail cam and the sector gear as shown in Figure 8. At a particular time t, the rotation angle of a sector gear turns a θ angle whilst the respective cam turns α angle. Initially the symmetrical line of the sector gear is at an angle of 30° to the vertical direction.

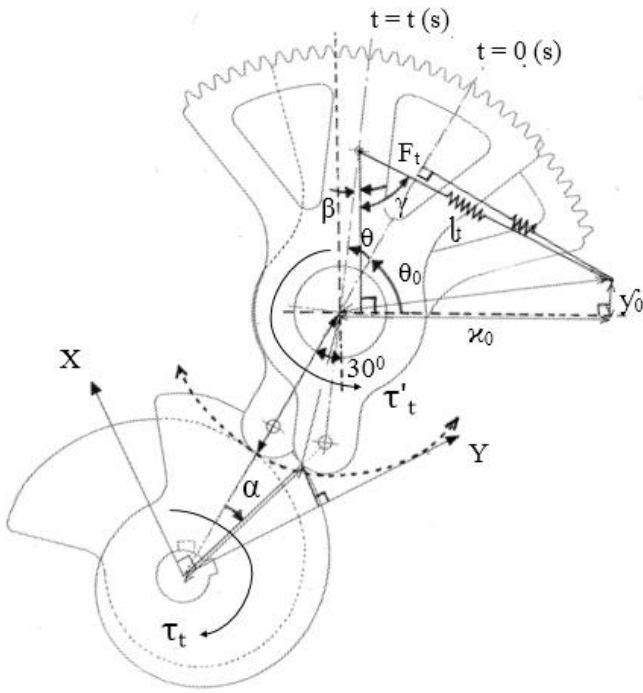

Figure 7 – Schematic diagram used for mathematical model

The resultant equations are as follows:

At $t = t(s)$;

$$x_t = \left(0.05 + \frac{0.12\alpha}{5\pi}\right) \sin \alpha$$

$$y_t = \left(0.05 + \frac{0.12\alpha}{5\pi}\right) \cos \alpha$$

The angle of rotation of the sector gear at $t = t(s)$ can be expressed as,

$$\theta = 2 \sin^{-1} \left[\frac{1}{2r_0} \left(0.05 + \frac{0.12\alpha}{5\pi}\right) \sin \alpha \right]$$

F_t denotes the spring force at $t = t(s)$ where K stands for the spring constant. l_f represents the free length of the spring.

$$F_t = K (l_t - l_f)$$

Torque on sector gear at that moment can be given as,

$$\tau_t = F \sin(\gamma + \beta) l_t$$

$$\tau_t = K l_t \left(1 - \frac{l_f}{l_t}\right) [x_0 \sin(\theta + \theta_0) - \cos(\theta + \theta_0)]$$

Torque on cam (τ'_t) at the same moment is given in terms of τ_t , r_0 , α and γ , given that,

$$\sin \gamma = \frac{1}{l_f} \left[x_0 - l_t \sin \left(\frac{\pi}{2} - (\theta + \theta_0) \right) \right]$$

$$\cos \gamma = \frac{1}{l_f} \left[l_t \cos \left(\frac{\pi}{2} - (\theta + \theta_0) \right) - y_0 \right]$$

$$\tau'_t = \left(0.05 + \frac{0.12\alpha}{5\pi}\right)^2 \cos \left\{ \tan^{-1} \left[\frac{-\left(\frac{25\pi}{12\alpha} + 1\right) \tan \alpha + 1}{\left(\frac{25\pi}{12\alpha} + 1\right) + \tan \alpha} \right] + \alpha \right\} \frac{\tau_t}{r_0 \cos(\gamma + \alpha)}$$

Using the derived equation from the mathematical model, the variation of the torques with the cam position is observed.

Figure 9 indicates the torque variation on pinion gears and flywheels for the spring constant (K) of 444 N/m with the cam position. The resultant torque on the flywheel 2 is always has a maximum value between 3 Nm and 3.5 Nm while the flywheel 1 has a maximum torque in between 1.5 Nm and 2 Nm. Torque on pinion gears is varying between 0 and 0.75 Nm.

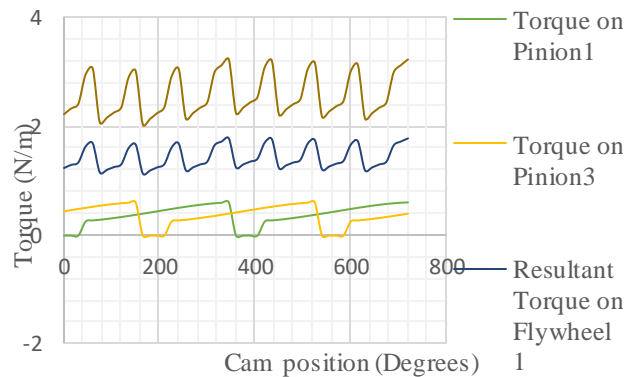

Figure 8 – Torque fluctuation along the pinion gears and flywheels, $K = 444 \text{ N/m}$

Figure 10 shows the torque acting on a single cam and the resultant torque on the cam shaft when all four cams are in action. Resultant torque is varying between 0.5 Nm and 6 Nm.

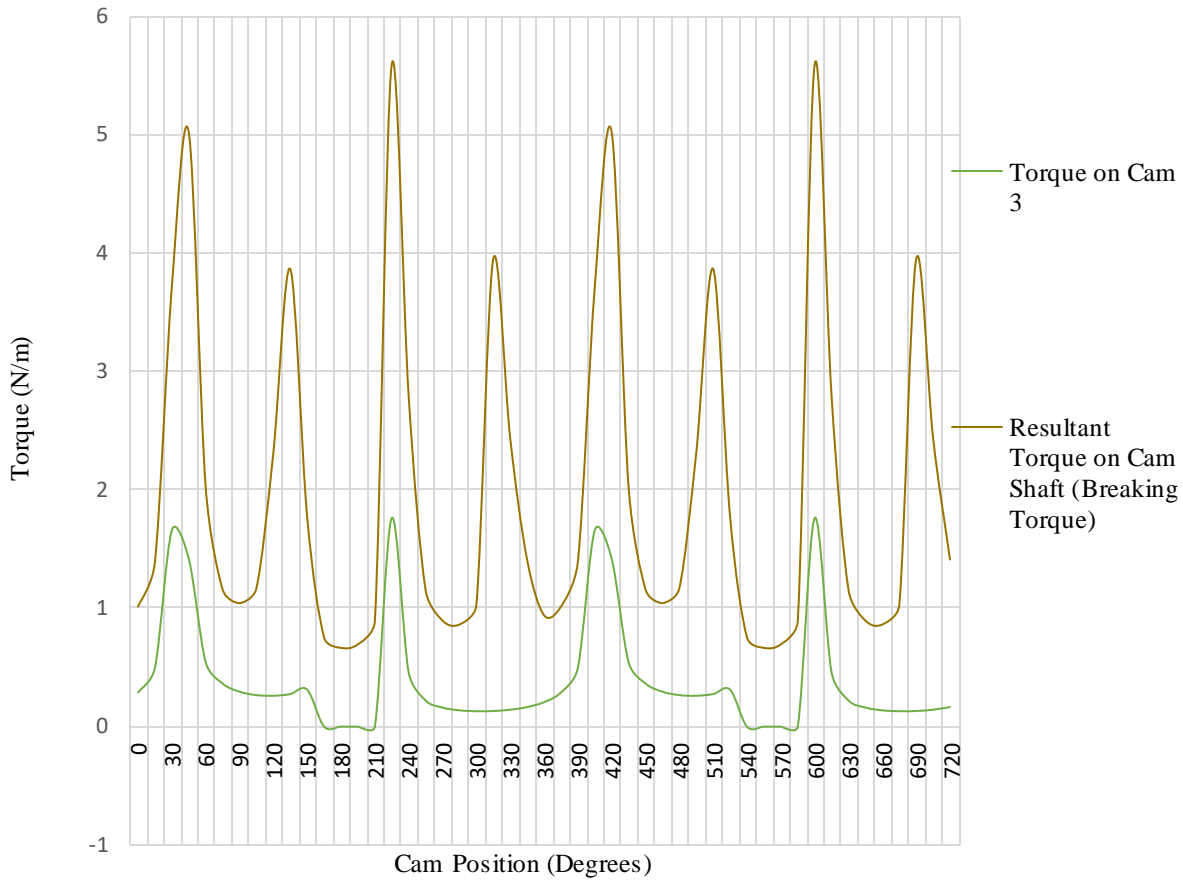

Figure 9 – Torque variation on cams and cam shaft with cam position, $K = 444 \text{ N/m}$

The same relationships are calculated for a system having 6 cams and another spring having a spring constant of 10000 N/m. The following figures are obtained using that data. Figure 11 shows that the resultant torque on flywheel 1 is always between 10 -15 Nm and the resultant torque on flywheel 2 is between 18 – 25 Nm. Here the calculations are done for a particular set of having 6 pinion gears. Torque on pinion two and six are always less than 4 Nm.

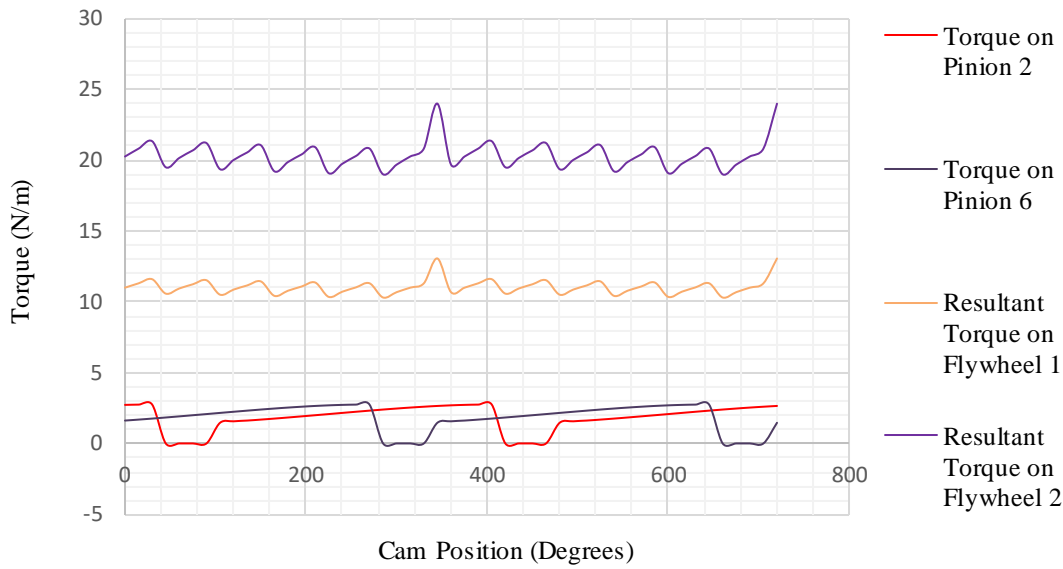

Figure 10 - Torque fluctuation along the pinion gears and flywheels, $K = 10000$ N/m

Figure 12 indicates that the torques on cam three and cam one are between 0 – 100 Nm. Resultant braking torque is always between 75 -225 Nm.

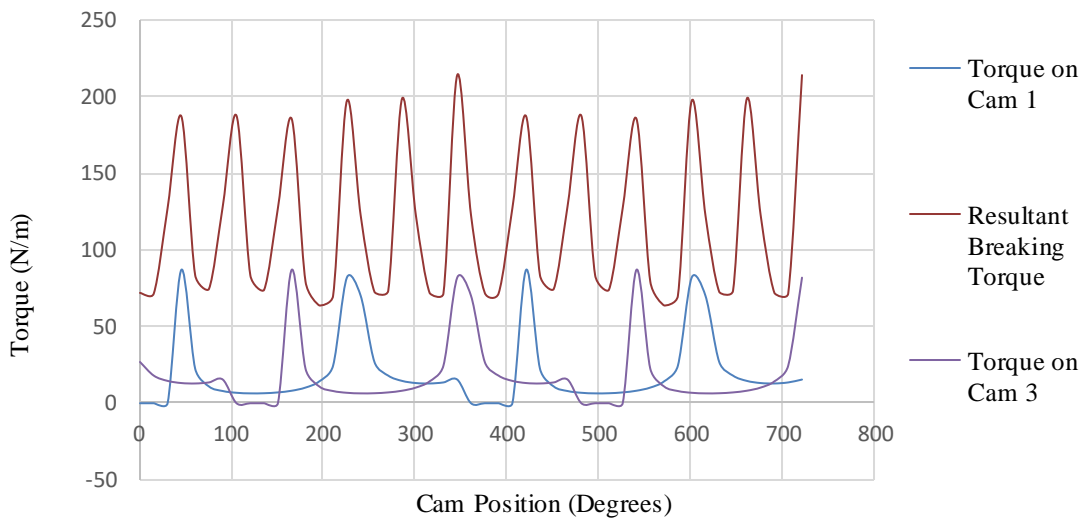

Figure 11 - Torque variation on cams and cam shaft with cam position, $K = 10000$ N/m

Simulink Model

Since it is found difficult to simulate the quick releasing scenario of the snail cam with the designing software the simulation was done using MATLAB Simulink model shown in Figure 13.

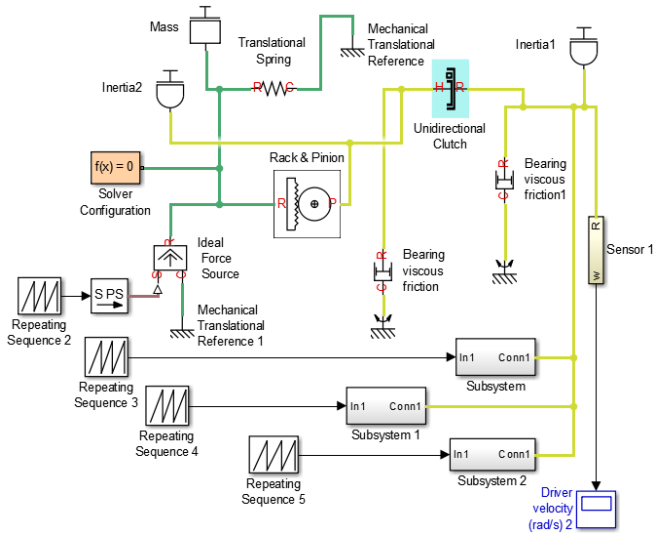

Figure 12 – MATLAB Simulink model

The quick releasing of the snail cam is given a repeating sequence of forces. Bearing friction is also added to the Simulink model. Flywheel is assumed as an inertia for the system. Using this model, it can be monitored maximum velocity of the energy storing flywheel for different springs with different spring constants. Figure 14 shows the variation in RPM of the flywheel with the time. RPM reaches a maximum value of 120 within 5 seconds and remain constant.

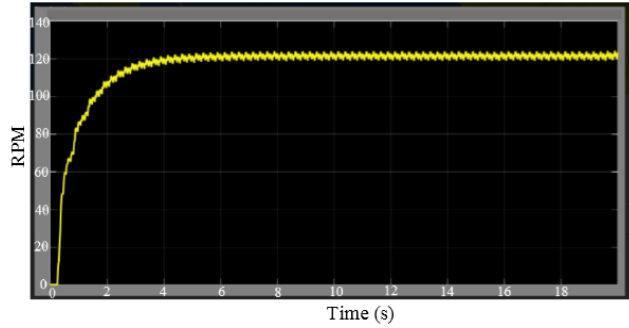

Figure 13 – Simulation results

Prototype Testing

The practical testing for the prototype is done using a spring which has a spring constant of 444.35 N/m. A tachometer is used to measure the rotational speeds of both flywheels. The energy storage flywheel reached to a maximum rotational speed within 5-6 seconds and kept rotating for about 25 seconds until it stops. Since the flywheels of the prototype are having complex geometries, SolidWorks software is used to obtain the values for the moment of inertia of both flywheels. Table 2 presents the obtained results.

Table 2 – Prototype testing results

I Source (kgm ²)	I storage (kgm ²)	RPM Source	RPM Storage	Energy (Source) (J)	Energy (Storage) (J)	Energy harvesting percentage
0.0156	0.0177	232	115	4.60	1.28	28%
0.0156	0.0177	219	113	4.10	1.24	30%
0.0156	0.0177	228	115	4.45	1.28	29%
0.0156	0.0177	225	113	4.33	1.24	29%
0.0156	0.0177	227	115	4.41	1.28	29%
0.0156	0.0177	235	118	4.72	1.35	29%

DISCUSSION

The prototype testing results indicates that there is huge area for improvements. The secondary stage prototype has reduced vibration and noise compared to the primary stage prototype. This is due to the usage of multiple snail cams instead of using one. This gives an approximately smoothed resultant torque to the drive shaft of the energy storing flywheel and therefore the vibration is reduced. However, still it experiences a certain amount of vibration. This could be reduced by further increasing the number of cams.

The material selection is done considering only the cost of manufacturing. Aluminum is easy to machine and is commonly available in many forms. Even though it is considered as a light metal, with all the other components including cast iron flywheels, electrical clutches and the supporting structure, the prototype is nearly 13 kg in weight. If a composite material with similar properties but with lesser density can be used to manufacture the components, the weight can be reduced by a significant amount. The flywheel used here is not specially designed for its ultimate task. The moment of inertia of the flywheel can be significantly increased by designing the flywheel in a way that majority of the matter is concentrated near the perimeter of the flywheel, yet having the same weight. The electrical clutches can be replaced by solenoid couplings saving lot of space and reducing the weight.

Further, considering the small time period that the flywheel is capable of rotating, it is obvious that a lot of friction forces are acting on it. However, use of magnetic bearings with the flywheel surrounded by a vacuum chamber will provide a better solution. With all these modifications, a developed prototype will perform better.

CONCLUSION

This project is mainly focused on introducing a new concept of kinetic energy harvesting from motor

vehicles. The primary prototype is used to check the conceptual mechanism was actually working. A secondary prototype is designed and constructed by eliminating the shortcomings of the primary prototype and by further developing it. The secondary prototype was then analysed theoretically by constructing a mathematical model and doing MATLAB simulation. Then it is tested practically to check the practical efficiency of energy harvesting. Since the prototype is made out of a lot of pre used and old components such as old electric clutches, worn out gear wheels and rusted fly wheels, it experiences a lot of energy losses. With all the energy losses due to friction, unbalance and slipping being considered, the actual prototype is capable of storing 29% of energy from the vehicle wheel as an average. After doing the mathematical simulation for the developed model by MATLAB Simulink, the energy storing efficiency is estimated to an average of 36%. It can be suggested that if the model is optimized, the efficiency will further increase.

This type of mechanism would be perfect and most useful for the instant power needs of motor vehicles such as sudden acceleration, or to run the air conditioner pump of the vehicle. This energy harvesting concept is pure to the industry at this moment but it would be possible to adduce this not only for the motor vehicles but also for other similar industrial applications.

ACKNOWLEDGEMENT

The laboratory facilities and project supervision from the Department of Mechanical Engineering, University of Moratuwa are highly appreciated.

REFERENCES

- Ajmal, A. and Ramachandaramurthy, V. (2015). Regenerative Braking of Electric Vehicle with Brushless DC Motor. *AMM*, 785, pp.280-284.



- Arthor, B., (2013.). *Hydraulic hybrids on the rise*.
[online] Hydraulicspneumatics.com.
Available at: <http://hydraulicspneumatics.com/200/TechZone/HydraulicPumpsM/Article/False/84554/TechZone-HydraulicPumpsM>
[Accessed 3 Jan. 2016].
- Bhagdikar, P., Gupta, S., Rana, N., and Jegadeeshwaran, R. (2014). Generation of electricity with the use of speed breakers. *International Journal of Advances in Engineering & Technology*, 7(2), pp.589-595.
- Courtney, B. and Klee, R. (n.d.). *Energy saving car suspension, Patent application GB0915807*.
[online] Cheshire - innovation.com.
Available at: http://www.cheshire-innovation.com/energy_saving_car_suspension.htm [Accessed 5 Feb. 2016].
- Clegg, S. (1996). *A Review of Regenerative Braking Systems - White Rose Research Online*.
[online] Eprints.whiterose.ac.uk. Available at: <http://eprints.whiterose.ac.uk/2118/>
[Accessed 5 Mar. 2016].
- Damor, A., Chaudhari, V., Tadvi, P. and Patel, R. (2012). An Experimental Study of Generation of Electricity Using Speed Breaker by Hydraulic Mechanism. *IJSR*, 2(11), pp.161-164.
- Dhand, A. and Pullen, K. (2014). Analysis of continuously variable transmission for flywheel energy storage systems in vehicular application. *Proceedings of the Institution of Mechanical Engineers, Part C: Journal of Mechanical Engineering Science*, 229(2), pp.273-290.
- Dhand, A. and Pullen, K. (2015). Review of battery electric vehicle propulsion systems incorporating flywheel energy storage. *International Journal of Automotive Technology*, 16(3), pp.487-500.
- Dunne, J. and Ponce Cuspinera, L. (2015). Optimal Gear Ratio Planning for Flywheel-Based Kinetic Energy Recovery Systems in Motor Vehicles. *Journal of Dynamic Systems, Measurement, and Control*, 137(7), p.071012.
- Epa.gov, (2014). Sources / Climate Change | US EPA. [online] Available at: <http://www.epa.gov/climatechange/ghgemissions/sources.html> [Accessed 6 Jun. 2014].
- Fujimoto, H. (2010). Development of efficient carbon anode material for a high-power and long-life lithium ion battery. *Journal of Power Sources*, 195(15), pp.5019-5024.



- Gantt, L. (2011). *Energy losses for propelling and braking conditions of an electric vehicle*. [Blacksburg, Va.]: [University Libraries, Virginia Polytechnic Institute and State University], pp.3-10.
- Himme, B. and O'Hanlon, T. (2016). *MECHANICS (MOTION) / FORCES - NAMES AND DIAGRAMS - Pathwayz*. [online] Pathwayz.org. Available at: <https://www.pathwayz.org/Tree/Plain/FORCES++NAMES+AND+DIAGRAMS> [Accessed 10 Mar. 2016].
- Hunt, J., Walter, J. and Hall, G. (1997). The effect of tread polymer variations on radial tire rolling resistance. In: *Tire rolling losses and fuel economy*
- Khalighi, B., Chen, K. H., and Iaccarino, G. (2012) Unsteady aerodynamic flow investigation around a simplified square-back road vehicle with drag reduction devices, *Journal of Fluids Engineering*, Vol.134(6), 061101
- Knowles, D. (2011). *Automotive suspension & steering systems*. Australia: Delmar, Cengage learning.
- Luo, X., Wang, J., Dooner, M. and Clarke, J. (2015). Overview of current development in electrical energy storage technologies and the application potential in power system operation. *Applied Energy*, 137, pp.511-536.
- Miège, A. and Popov, A. (2005). *Truck tyre modelling for rolling resistance calculations under a dynamic vertical load*.
- Murchison, J. (2011). *How powerful of a motor do you need to run an alternator?*. [online] Instructables.com. Available at: <http://www.instructables.com/answers/How-powerful-of-a-motor-do-you-need-to-run-an-alte/> [Accessed 3 Feb. 2016].
- Rohatgi, U. S. (2012), Methods of reducing vehicle aerodynamic drag, ASME 2012 Summer Heat Transfer Conference, Puerto Rico, USA, July 8-12.
- Sharma, R. B., and Bansal, R. (2013) CFD simulation for flow over passenger car using tail plates for aerodynamic drag reduction, *IOSR Journal of Mechanical and Civil Engineering (IOSR-JMCE)*, Vol. 7, No. 5, pp 28-35



International Conference on Engineering and Technology

Vazquez, S., Lukic, S., Galvan, E., Franquelo, L. and Carrasco, J. (2010). Energy Storage Systems for Transport and Grid Applications. *IEEE Transactions on Industrial Electronics*, 57(12), pp.3881-3895.

Volkswagen (2011). *Volkswagen Group Powertrain and Energy Carriers*. [online] Volkswagenag.com. Available at: <http://www.volkswagenag.com/content/vwcorp/content/en>

/innovation/Powertrain_and_Energy_Carriers.html [Accessed 18 Feb. 2016].

Wong, J. (2008). *Theory of ground vehicles*. 4th ed. New York: Wiley.

Zuo, L. and Zhang, P. (2013). Energy Harvesting, Ride Comfort, and Road Handling of Regenerative Vehicle Suspensions. *Journal of Vibration and Acoustics*, 135(1), p.011002.