

# ලංකා රජයේ ගැසට් පත්‍රය

## THE CEYLON GOVERNMENT GAZETTE

අංක 14,472 — 1965 අගෝස්තු 6 වැනි සිකුරාදා — 1965.8.6

No. 14,472—FRIDAY, AUGUST 6, 1965

(Published by Authority)

### PART I: SECTION (III)—TRADE MARK AND PATENT NOTICES

(Separate paging is given to each language of every Part in order that it may be filed separately)

|   | PAGE |   | PAGE |
|---|------|---|------|
| Trade Mark Notices .. ..                        | 163  | Notifications under the Designs Ordinance .. .. | —    |
| Trade Mark Notifications .. ..                  | —    | Miscellaneous .. ..                             | —    |
| Notifications under the Patents Ordinance .. .. | 167  |   |      |

Note.—The Bribery Amendment Act, No. 2 of 1965 and the Ceylon Railway Daily-paid Worker's Benevolent Association (Incorporation) Act, No. 3 of 1965, appear as a Supplement to Part II of this issue.

#### Trade Mark Notices

##### Trade Marks Office

All communications relating to Trade marks should be addressed to the Registrar of Trade marks, Department of the Registrar of Companies, Block 5, Echelon Square, Colombo 1.

##### Hours of Inspection

The office shall be open to the public every week day, except Saturday, between the hours of ten to four, and on Saturdays between the hours of ten to one, except on public holidays. Applications for inspections will, however, be accepted up to 3 p.m. on week days and 12 noon on Saturdays.

##### Trade Marks limited to Colours

Where it is stated in the advertisement of an application that the mark upon its registration is to be limited to

certain colours, the colours are, as far as possible, indicated in the accompanying representation of the mark in the usual heraldic manner.

##### Association

Where it is stated that an advertised mark is to be associated (under Section 22 of the Trade Marks Ordinance (Cap. 121), with another mark, it is indicated by its official number.

##### Applications in Part A or Part B

Applications for registration in Part A of the Register are shown with the official number unaccompanied by any letter. Applications for Part B of the Register are distinguished by the letter B prefixed to the official number

#### OPPOSITION

NOTICE is hereby given that any person who has grounds of objection to the registration of the following trade marks may, within two months from the date of this Gazette, lodge Notice of Opposition on form T. M. No. 7 bearing an uncanceled or impressed stamp of Rs. 25. The period of lodging Notice of Opposition may be enlarged by the Registrar if he thinks fit and upon such terms as he may direct.

Formal opposition should not be lodged until after reasonable notice has been given by letter to the Applicant for registration so as to afford him an opportunity of withdrawing his application before the expense of preparing the Notice of Opposition is incurred. Failure to give such notice will be taken into account in considering any application by an Opponent for an Order of Costs if the opposition is uncontested by the Applicant.

#### IMPORTANT NOTICE

It is hereby notified that in view of the Public Holiday on Wednesday, August 11, 1965, all Notices and Advertisements for publication in the Ceylon Government Gazette of August 13, 1965, should reach the Government Press not later than 12 noon on Saturday, August 7, 1965.

Government Press,  
Colombo, August 3, 1965.

BERNARD de SILVA,  
Government Printer.

**TRADE MARK APPLICATIONS ADVERTISED BEFORE REGISTRATION**

(The Trade Marks Office does not guarantee the accuracy of these publications or undertake any responsibility for errors or omissions or their consequences.)

(1) Trade Mark No. 26,422. (2) Date of Receipt: 28th January, 1965. (3) Applicant (Proprietor of the Trade Mark): UNILEVER LIMITED (a British Company) Port Sunlight, Cheshire, England; manufacturers. (4) Address for service in the Island: G. Jayasuriya, 258, Grandpass Road, Colombo 14. (5) Class: 47. (6) Goods: Soaps and detergents for household purposes. (7) Representation of the Trade Mark.



1. Registration of this mark shall give no right to the exclusive use of the device of the washing machine.
2. This mark is associated with trade mark No. 20,063.

W. M. SELLAYAH,  
Registrar of Trade Marks.

Department of Registrar of Companies,  
Colombo, 21st May, 1965.

8-1167

(1) Trade Mark No. 26,470. (2) Date of Receipt: 24th February, 1965. (3) Applicant (Proprietor of the Trade Mark): MERAGALPEDIGEDARA HARISON, Kannadeniya, Kaha-pathwela; manufacturer and dealer. (4) Address for service in the Island: —. (5) Class: 45. (6) Goods: Beedies, (7) Representation of the Trade Mark.



1. Registration of this trade mark shall give no right to the exclusive use of the surname Harison, numeral 500 and the device of the lady holding the packet of beedies.

W. M. SELLAYAH,  
Registrar of Trade Marks.

Department of Registrar of Companies,  
Colombo, 19th June, 1965.

8-1166

(1) Trade Mark No. 26,178. (2) Date of Receipt: 16th October, 1964. (3) Applicant (Proprietor of the Trade Mark): MALLAWA ARACHCHIGE SIRISENA, JOHN VICTOR DE SARAM, MRS. SOMA MALLAWAARACHCHI, JAMBURUGODA GAMAGE JINADASA AND SAPARAMADU DON EARNEST MAYADUNNE trading as 'Nanda Tobacco Industries', 251, Colombo Road, Gampaha; manufacturers. (4) Address for service in the Island: —. (5) Class: 45. (6) Goods: Cigars. (7) Representation of the Trade Mark.

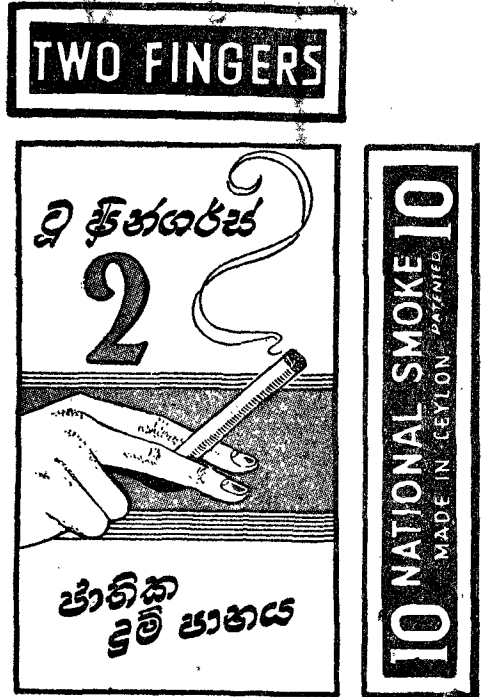

1. Registration of this trade mark shall give no right to the exclusive use of the device of the lighted cigar, the words 'National Smoke' and the numerals 2 and 10.

W. M. SELLAYAH,  
Registrar of Trade Marks.

Department of Registrar of Companies,  
Colombo, 8th March, 1965.

8-1164

(1) Trade Mark No. 25,672. (2) Date of Receipt: 28th April, 1964. (3) Applicant (Proprietor of the Trade Mark): CADBURY BROTHERS, LIMITED (a British Company); Bournville, Birmingham, England; manufacturers. (4) Address for service in the Island: Messrs. Julius & Creasy, P. O. Box 154, Colombo. (5) Class: 42. (6) Goods: Chocolate, chocolates; chocolate confectionery and sugar confectionery (none being medicated); and chocolate biscuits. (7) Representation of the Trade Mark:



1. Registration of this trade mark shall give no right to the exclusive use of the words BAR SIX.
2. This trade mark is to be associated with trade mark Nos. 3,584, 14,520, 16,776, 22,546, 25,096, 24,299 and 24,298.

W. M. SELLAYAH,  
Registrar of Trade Marks.

Department of Registrar of Companies,  
Colombo, 28th December, 1964.

8-840

(1) Trade Mark No. 26,580. (2) Date of Receipt: 25th March, 1965. (3) Applicant (Proprietor of the Trade Mark): KANE-GAFUCHI BOSEKI KABUSHIKI KAISHA, trading as Kane-gafuchi Spinning Co., Ltd., (a Joint-stock company organised under the laws of Japan) of 3-26, 3-chome, Tsutsumi-dori, Sumida-ku, Tokyo, Japan and 123, Tomobuchi-cho, Miyakojima-ku, Osaka, Japan; manufacturers and merchants. (4) Address for service in the Island: Messrs. Julius & Creasy, P. O. Box 154, Colombo 1. (5) Class: 50. (6) Goods: Rayon yarns, synthetic fibre yarns. (7) Representation of the Trade Mark:

**Kanebo**

W. M. SELLAYAH,  
Registrar of Trade Marks.

Department of Registrar of Companies,  
Colombo, 1st June, 1965.

8-1161

(1) Trade Mark No. 25,180. (2) Date of Receipt: 4th December, 1963. (3) Applicant (Proprietor of the Trade Mark): TEIJIN LIMITED (a Corporation organised under the laws of Japan) of No. 1, Umeda, Kita-ku, Osaka, Japan; manufacturers and merchants. (4) Address for service in the Island: Messrs. Julius & Creasy, P. O. Box 154, Colombo 1. (5) Class: 50. (6) Goods: Chemical fibres; yarns and threads, textile fabrics, and clothing, all made wholly or predominantly of chemical fibres; ropes, nets, tents, sails, all made wholly or predominantly of chemical fibres. (7) Representation of the Trade Mark:

**Teviron**

1. This mark is associated with trade mark No. 21,852.

W. M. SELLAYAH,  
Registrar of Trade Marks.

Department of Registrar of Companies,  
Colombo, 30th April, 1965.

8-1162

(1) Trade Mark No. 25,816. (2) Date of Receipt: 17th June, 1964. (3) Applicant (Proprietor of the Trade Mark): MEIJI MILK PRODUCTS CO., LTD. (a Corporation organized under the laws of Japan); No. 6, 2-chome, Kyobashi, Chuo-Ku, Tokyo, Japan; manufacturers and merchants. (4) Address for service in the Island: Messrs. Julius & Creasy, P. O. Box 154, Colombo. (5) Class: 42. (6) Goods: Milk products (especially, sweetened condensed milk, powdered milk and evaporated milk). (7) Representation of the Trade Mark:

**明治**

Transliteration and transliteration of the non-English word is "Meiji".

This trade mark is to be associated with trade mark application No. 25,819 if and when registered.

W. M. SELLAYAH,  
Registrar of Trade Marks.

Department of Registrar of Companies,  
Colombo, 1st April, 1965.

8-839

(1) Trade Mark No. 25,819. (2) Date of Receipt: 17th June, 1964. (3) Applicant (Proprietor of the Trade Mark): MEIJI MILK PRODUCTS CO., LTD. (a Corporation organized under the laws of Japan); No. 6, 2-Chome Kyobashi, Chuo-ku, Tokyo, Japan; manufacturers and merchants. (4) Address for service in the Island: Messrs. Julius & Creasy, P. O. Box 154, Colombo. (5) Class: 42. (6) Goods: Milk products (especially, sweetened condensed milk, powdered milk and evaporated milk). (7) Representation of the Trade Mark:

**Meiji**

This trade mark is to be associated with trade mark application No. 25,816 if and when registered.

W. M. SELLAYAH,  
Registrar of Trade Marks.

Department of Registrar of Companies,  
Colombo, 1st April, 1965.

8-842

(1) Trade Mark No. 25,898. (2) Date of Receipt: 8th July, 1964. (3) Applicant (Proprietor of the Trade Mark): CEYLON SYNTHETIC TEXTILE MILLS LIMITED (a Company duly incorporated in Ceylon), 752, Baseline Road, Colombo 9; manufacturers and merchants. (4) Address for service in the Island: Messrs. Abrahams, 243, Hultsdorp Street, Colombo 12. (5) Class: 50. (6) Goods: Synthetic fabrics. (7) Representation of the Trade Mark:

**Tetryn**

W. M. SELLAYAH,  
Registrar of Trade Marks.

Department of Registrar of Companies,  
Colombo, 26th May, 1965.

8-1169

(1) Trade Mark No. 25,900. (2) Date of Receipt: 8th July, 1964. (3) Applicant (Proprietor of the Trade Mark): CEYLON SYNTHETIC TEXTILE MILLS LIMITED (a Company duly incorporated in Ceylon), 752, Baseline Road, Colombo 9; manufacturers and merchants. (4) Address for service in the Island: Messrs. Abrahams, 243, Hultsdorp Street, Colombo 12. (5) Class: 50. (6) Goods: Synthetic fabrics. (7) Representation of the Trade Mark:

**Cyntex**

W. M. SELLAYAH,  
Registrar of Trade Marks.

Department of Registrar of Companies,  
Colombo, 1st June, 1965.

8-1170

(1) Trade Mark No. 25,671. (2) Date of Receipt: 23rd April, 1964. (3) Applicant (Proprietor of the Trade Mark): VEB ARZNEIMITTELWERK DRESDEN (a National Corporation organized under the laws of Germany), Radebuel 1, Wilhelm Pieck-Strasse, 35, German Democratic Republic; manufacturers. (4) Address for service in the Island: Mr. V. Murugesu, Hemas Building, York Street, Colombo. (5) Class: 3. (6) Goods: Pharmaceutical preparations. (7) Representation of the Trade Mark:

**MERCALEUKIN**

W. M. SELLAYAH,  
Registrar of Trade Marks.

Department of Registrar of Companies,  
Colombo, 2nd July, 1965.

8-844

1. Trade Mark No. 26108. 2. Date of Receipt: 11th September, 1964. 3. Applicant (Proprietor of the Trade Mark: PURE BEVERAGES COMPANY LIMITED (a Company organized under the Companies Ordinance of Ceylon); 74, Union Place, Colombo 2; Manufacturers. 4. Address for service in the island: M/s. Julius & Creasy, P. O. Box 154, Colombo. 5. Class: 44. 6. Goods: Aerated waters. 7. Representation of the Trade Mark:



1. *Sinhala:* Transliteration: Sinha Narang Translation: Sinha Narang

2. Registration of this Trade Mark shall give no right to the exclusive use of the Fruit and word Narang.

3. This trade mark is to be associated with trade mark Nos. 8376, 8937, 10679, 14818, 16791, 16792, 16793, 16794, 16795, 16796, 16797, 16798, 16799, 16800, 16801, 16832, 16802, 16804, 16805, 16806, 16807, and 23063.

Department of Registrar of Companies,  
Colombo, February, 12, 1965.  
8-841

W. M. SELLAYAH,  
Registrar of Trade Marks.

(1) Trade Mark No. 25,667. (2) Date of Receipt: 28th April, 1964. (3) Applicant (Proprietor of the Trade Mark): VEB ARZNEIMITTELWERK DRESDEN (a National Corporation organised under the laws of the German Democratic Republic) Radebeul 1, Wilhelm Pieck-Strasse, 35, German Democratic Republic; manufacturers. (4) Address for service in the Island: Mr. V. Murugesu, Hemas Building, York Street, Colombo 1. (5) Class: 3. (6) Goods: Pharmaceutical preparations. (7) Representation of the Trade Mark:

KINETOSIN

W. M. SELLAYAH,  
Registrar of Trade Marks.

Department of Registrar of Companies,  
Colombo, 2nd July, 1965.

8-843

(1) Trade Mark No. 26,563. (2) Date of Receipt: 25th March, 1965. (3) Applicant (Proprietor of the Trade Mark): SHIKI-SHIMA SPINNING CO., LTD. (a Company duly organised under the laws of Japan); No. 34, 4-chome, Bingomachi, Higashi-ku, Osaka, Japan; manufacturers and merchants. (4) Address for service in the Island: V. Murugesu Esqr., Hemas Building, York Street, Colombo 1. (5) Class: 25. (6) Goods: Cotton goods not included in other classes. (7) Representation of the Trade Mark:

Shikibo

W. M. SELLAYAH,  
Registrar of Trade Marks.

Department of Registrar of Companies,  
Colombo, 17th May, 1965.

8-846

(1) Trade Mark No. 25,642. (2) Date of Receipt: 17th April, 1964. (3) Applicant (Proprietor of the Trade Mark): VEB ARZNEIMITTELWERK DRESDEN (a National Corporation organised under the laws of the German Democratic Republic), Radebeul 1, Wilhelm Pieck-Strasse, 35, German Democratic Republic; manufacturers. (4) Address for service in the Island: Mr. V. Murugesu, Hemas Building, York Street, Colombo 1. (5) Class: 3. (6) Goods: Pharmaceutical preparations. (7) Representation of the Trade Mark:

CEGLUNAT

W. M. SELLAYAH,  
Registrar of Trade Marks.

Department of Registrar of Companies,  
Colombo, 2nd July, 1965.

8-845

(1) Trade Mark No. 25,643. (2) Date of Receipt: 17th April, 1964. (3) Applicant (Proprietor of the Trade Mark): VEB ARZNEIMITTELWERK DRESDEN (a National Corporation organised under the laws of the German Democratic Republic), Radebeul 1, Wilhelm Pieck-Strasse, 35, German Democratic Republic; manufacturers. (4) Address for service in the Island: Mr. V. Murugesu, Hemas Building, York Street, Colombo 1. (5) Class: 3. (6) Goods: Pharmaceutical preparations. (7) Representation of the Trade Mark:

DISALUNIL

W. M. SELLAYAH,  
Registrar of Trade Marks.

Department of Registrar of Companies,  
Colombo, 2nd July, 1965.

8-846

**Notifications under the Patents Ordinance**

**NOTICE**

THE following specification has been accepted :—  
No. 5,359 of 10th January, 1964. (Convention application claiming priority date 17.1.63 of U. K. No. 2,177/63).

BATTELLE MEMORIAL INSTITUTE.  
"Improvements relating to smoking devices".

Abstract.—The nature of the invention can be ascertained from claim 1 which reads as follows :—

1. A smoking device comprising a mouthpiece, a container or carrier provided with a source material capable of releasing nicotine vapour and aerosol-forming vapour when heated, a material, separated from or other than the said source material, which by its combustion or other exothermal reaction is adapted for heating the said source material to a temperature below the ignition point of the latter material to cause the release therefrom of the said vapours, and an aerosol-nucleating space communicating with the said mouthpiece and either communicating with or formed by part of the said container or carrier in such a manner that air can be drawn through or over the heated source material and through the said space to the mouthpiece.

There are 30 claims and 2 sheets of drawings.

S. L. DE SILVA,  
Registrar of Patents.

Colombo, June 4, 1965.

8—1197/1

**NOTICE**

THE following specification has been accepted :—

No. 5,363 of 22nd January, 1964.  
THE DOW CHEMICAL COMPANY.

"Nitrogen compounds of polychloro-2-(Trichloromethyl) pyridines".

Abstract.—The nature of the invention can be ascertained from claim 1 which reads as follows :—

1. The compounds of the group consisting of the 4-amino-polychloro-2-(trichloromethyl) pyridine compounds having the formula—

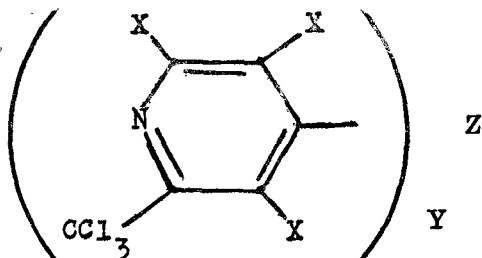

and their acid addition salts, wherein in the formula, y is an integer, each X is hydrogen or chloro and at least two of the X's are chloro, and Z is the residue of a nitrogen base having a basic dissociation constant greater than 10<sup>-7</sup> and having at least one HN group in which each of the free valences is connected to carbon, hydrogen or nitrogen.

There are 12 claims and 11 Examples.

S. L. DE SILVA,  
Registrar of Patents.

Colombo, June 12, 1965.

8—1197/2

**NOTICE**

THE following specification has been accepted :—

No. 5,365 of 22nd January, 1964.

PIERRELL S. p. A.

"Water-soluble salt of erythromycin".

Abstract.—The nature of the invention can be ascertained from claims 1 and 2 which read as follows :—

1. A new composition of matter represented by the new chemical compound erythromycin lactate which, in a partial or aqueous solution is therapeutically used mainly for parenteral administration.

2. Process for the production of erythromycin lactate essentially consisting in reacting an erythromycin solution in an organic solvent or in a mixture of organic solvents with an equivalent amount or an excess of lactic acid.

There are 9 claims and 9 examples.

S. L. DE SILVA,  
Registrar of Patents.

Colombo, June 12, 1965.

8—1197/3

**NOTICE**

THE following specification has been accepted :—

No. 5,366 of 22nd January, 1964.

THE DOW CHEMICAL COMPANY.

"Amino-Trichloropicolinic acid compounds".

Abstract.—The nature of the invention can be ascertained from claim 1 which reads as follows :—

1. An aminotrichloropicolinic acid compound having the formula—

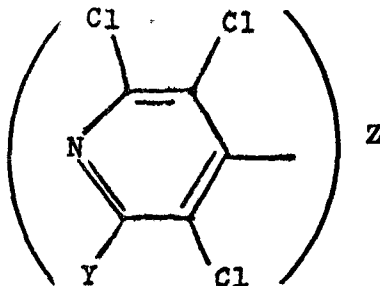

wherein Y is a carboxylic acid group or functional derivative thereof and Z is the residue of a nitrogen base having a dissociation constant greater than 10<sup>-7</sup> and having at least one N<sup>1</sup> group, wherein each of the free valences is connected to carbon, hydrogen or nitrogen.

There are 21 claims and 22 examples.

S. L. DE SILVA,  
Registrar of Patents.

Colombo, June 12, 1965.

8—1197/4

**NOTICE**

THE following specification has been accepted :—

No. 5,373 of 3rd February, 1964.

ASCHAFFENBURGER ZELLSTOFFWERKE AKTIEN-GESELLSCHAFT.

"Process for production of newsprint by application of pulp from hevea wood, which is used in the form of chips, slightly decomposed by soda lye".

Abstract.—The nature of the invention can be ascertained from claims 1, 2 and 3 which read as follows :—

1. Process for production of newsprint by application of a pulp-like product from chips, which are impregnated with diluted soda lye and treated with the latter for 1-5 hours, characterised in that the wood of Hevea Brasiliensis is used as basis.

2. Process as claimed in Claim 1 characterised in that the product obtained in this way is bleached with 5-15 per cent chlorine in form of hypochlorite without buffering or with a slight buffering.

3. Process as claimed in Claims 1 and 2, characterised in that pressure shocks or vacuum treatment are applied for impregnation.

There are 7 claims.

S. L. DE SILVA,  
Registrar of Patents.

Colombo, June 29, 1965.

8—1197/5

**NOTICE**

THE following specifications have been accepted :—

No. 5,381 of 19th February, 1964. (Registration of U. K. Patent 878,527 of 18.12.59 under Section 46).

IMPERIAL CHEMICAL INDUSTRIES LIMITED.

"New metallised monoazo dyestuffs containing halogenotriazynylamino groups".

Abstract.—The nature of the invention can be ascertained from claim 1 which reads as follows:—

1. As new metallised azo dyestuffs the chromium and cobalt complexes of the azo compounds which, in the form of the free acids are represented by the formula—

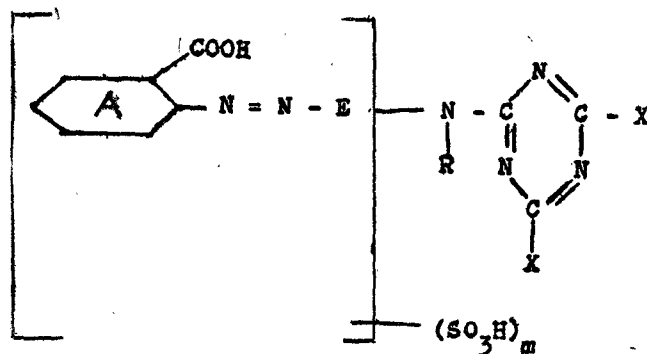

wherein the benzene ring A may be further substituted, E represents the residue of a coupling component which couples in an ortho position to a hydroxy group or in an adjacent position to an enolisable keto group, R represents a hydrogen atom or an alkyl radical containing not more than 4 carbon atoms, X represents a chlorine or a bromine atom and m represents 1 or 2.

There are 11 claims and 36 examples.

S. L. DE SILVA,  
Registrar of Patents.

Colombo, June 17, 1965.

8—1197/6

NOTICE

THE following specification has been accepted:—

No. 5,383 of 19th February, 1964. (Registration U. K. Patents 916,644 of 7.5.59).

FARBWERKE HOECHST AKTIENGESELLSCHAFT  
VORMALS MEISTER LUCIUS AND BRUNING.  
“Basically substituted diphenyl-methane compounds and process for their manufacture”.

Abstract.—The nature of the invention can be ascertained from claim 1 which reads as follows:—

1. Diphenyl-methane compounds of the general formula—

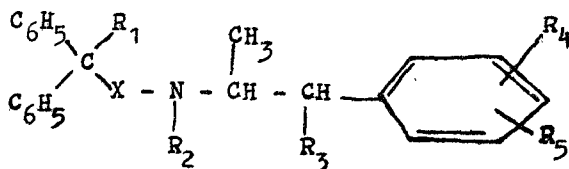

in which X represents a straight-chain or branched aliphatic hydrocarbon radical containing at most 3 carbon atoms, R<sub>1</sub> represents a hydrogen atom or an alkyl group (C<sub>1-4</sub>), R<sub>2</sub> represents a hydrogen atom or a methyl group, R<sub>3</sub> represents a hydrogen atom or a hydroxyl group, R<sub>4</sub> and R<sub>5</sub> each represent a hydrogen atom, a hydroxyl group or a methoxy group.

There are 24 claims and 15 examples.

S. L. DE SILVA,  
Registrar of Patents.

Colombo, June 17, 1965.

8—1197/7

NOTICE

THE following specification has been accepted:—

No. 5,391 of 2nd March, 1964. (Registration of U. K. No. 927,772 of 5.9.60.)

IMPERIAL CHEMICAL INDUSTRIES LIMITED.  
“New textile colouring process”.

Abstract.—The nature of the invention can be ascertained from claim 1 which reads as follows:—

1. Process for colouring textile materials which comprise treating the said textile materials with a dyestuff which contains at least one group of the formula—



wherein A represents an oxygen or a sulphur atom or a NY group wherein Y represents a hydrogen atom or a substituted or unsubstituted alkyl radical or a cycloalkyl radical, and Z represents a heterocyclic ring which contains at least one—

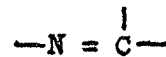

group and which is attached to A through a carbon atom of the heterocyclic ring, and which carries attached to a carbon atom or atoms of the heterocyclic ring at least one group of the formula—

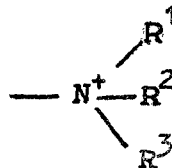

wherein R<sup>1</sup> and R<sup>2</sup> each represents a methyl radical and R<sup>3</sup> represents a substituted or unsubstituted aliphatic hydrocarbon radical, or at least two of R<sup>1</sup>, R<sup>2</sup> and R<sup>3</sup> are joined or fused together to form with the nitrogen atom N a heterocyclic ring or rings so that the nitrogen atom is linked to carbon atoms present in the said heterocyclic ring or rings through either single bonds or through a single bond and a double bond, provided that the said

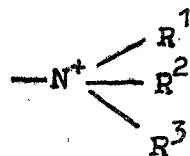

group is free from sulphonic acid groups.

There are 21 claims and 105 Examples.

S. L. DE SILVA,  
Registrar of Patents.

Colombo, June 17, 1965.

8—1197/8

NOTICE

THE following specification has been accepted:—

No. 5,396 of 13th March, 1964. (Registration of U. K. Patent No. 813,861 of 15.11.56, under Section 46).

SMITH KLINE AND FRENCH LABORATORIES

“Improvements in or relating to 10-(Aminoalkyl)-Trifluoro-Methyl Phenothiazine Derivatives”.

Abstract.—The nature of the invention can be ascertained from Claim 1 which reads as follows:—

1. Chemical compounds of the class consisting of a free base and its non-toxic salts, the free base having the formula —

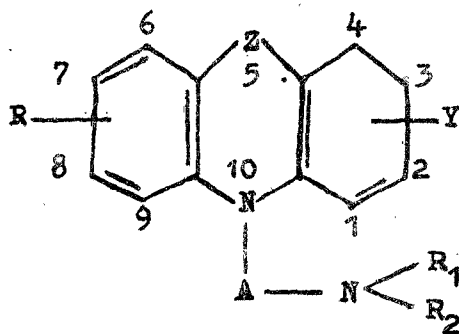

in which Z is -S- or -SO-; Y is trifluoromethyl; R is hydrogen, halogen, trifluoromethyl, lower alkyl or lower alkoxy; A is a divalent aliphatic hydrocarbon chain containing 2 to 6 carbon atoms, R<sub>1</sub> and R<sub>2</sub> are hydrogen or lower alkyl or, when taken together with the nitrogen to which they are attached, form a five- to six-membered heterocyclic ring.

There are 11 claims and 36 Examples.

Reference has been directed in pursuance of Section 9, subsection (6), of the Patents Ordinance, to the following specification of letters patent No. 4404 granted to Olin Mathieson Chemical Corporation and dated 23.12.55.

The applicants state that "We are now aware of Ceylon Patent specification 4,404 which also relates to phenothiazine compounds, which specification was not published at the application date of British Patent No. 813,861".

S. L. DE SILVA,  
 Registrar of Patents.

Colombo, June 11, 1965.

8-1197/9

**NOTICE**

THE following specification has been accepted:—

No. 5,397 of 13th March, 1964. (Registration of U. K. No. 935,426 of 15.3.61). Under Section 46.

IMPERIAL CHEMICAL INDUSTRIES LIMITED.

"Compositions comprising or consisting of a coated chloroquine or amodiaquine salt".

*Abstract.*—The nature of the invention can be ascertained from claim 1 which reads as follows:—

1. Particulate pharmaceutical compositions consisting of a chloroquine or amodiaquine salt in particulate form which is coated with one or more non-toxic orally-acceptable coating agents selected from waxy or fatty substances having a melting point between 37°C. and 120°C., liquid mineral or vegetable oils, liquid hydrogenated vegetable or animal oils, and natural or synthetic resins having a melting point between 37°C and 120°C.

There are 20 claims 14 examples.

S. L. DE SILVA,  
 Registrar of Patents.

Colombo, June 17, 1965.

8-1197/10

**NOTICE**

THE following specification has been accepted:—

No. 5,407 of 9th April 1964. (Registration of U. K. 860,303 of 22.5.59). Under Section 46.

IMPERIAL CHEMICAL INDUSTRIES LIMITED.

"Pharmaceutical compositions comprising α-aryloxy—aliphatic carboxylic acids and/or α-arylimino-aliphatic carboxylic acids, their esters and salts".

*Abstract.*—The nature of the invention can be ascertained from claim 1 which reads as follows:—

1. Pharmaceutical compositions containing as active ingredient at least one compound of the formula—

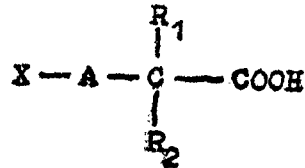

wherein A stands for oxygen or for the imino radical, R<sub>1</sub> and R<sub>2</sub>, which may be the same or different, stand for hydrogen or for alkyl radicals, or they may be joined to form, together with the adjacent carbon atom, a cycloalkyl ring, and X stands for a phenyl or naphyl radical which may optionally be substituted by one, two or three substituents which may be the same or different and which are selected from halogen atoms and alkyl, alkenyl, alkoxy, aryl, aralkyl, aralkoxy and arylamino radicals, or the esters or salts thereof, together with a non-toxic pharmaceutically-acceptable inert diluent or carrier, provided that the inert diluent or carrier is not water or an organic solvent.

There are 11 claims and 21 examples.

S. L. DE SILVA,  
 Registrar of Patents.

Colombo, June 17, 1965.

8-1197/11

**NOTICE**

THE following specification has been accepted:—

No. 5,410 of 17th April, 1964.

DON JOHN TERRENCE JAYASINGHE.

"Hydraulic brake fluid".

*Abstract.*—The invention relates to a hydraulic brake fluid for use on vehicles formed by the mixing of one twelfth vegetable seed oil, five twelfths pure alcohol; two twelfths rubber seed oil and four twelfths castor seed oil.

There is one claim.

S. L. DE SILVA,  
 Registrar of Patents.

Colombo, June 22, 1965.

8-1197/12

The "Ceylon Government Gazette" is published every Friday. Day of publication is subject to alteration in any week where Public Holidays intervene.

All Notices and Advertisements should reach the Government Printer, Government Press, Colombo, by 3.30 p.m. four working days previous to day of publication (i.e., normally 3.30 p.m. on Monday).

Subscriptions for the "Government Gazette" should be paid direct to the Superintendent, Government Publications Bureau, Secretariat, Colombo. The Government Printer does not accept subscriptions for the "Gazette".

**SCALE OF CHARGES FOR NOTICES AND ADVERTISEMENTS**

**CEYLON GOVERNMENT GAZETTE**

(Issued every Friday)

1. All Notices and Advertisements are published at the risk of the Advertisers.
2. All Notices and Advertisements by Private Advertisers may be handed in or sent direct by post together with full payment to the Government Printer, Government Press, Colombo
3. The office hours are from 9 a.m. to 4.30 p.m. on week days and 9 a.m. to 1 p.m. on Saturdays.
4. Cash transactions close at 3.30 p.m. on week days and at 12 noon on Saturdays.
5. All Notices and Advertisements must be prepaid. Notices and Advertisements sent direct by post should be accompanied by Money Order, Postal Order or Cheque, made payable to the Government Printer. Postage stamps will not be accepted in payment of advertisements.
6. To avoid errors and delay, "copy" should be on one side of the paper only and preferably typewritten.
7. All signatures should be repeated in block letters below the written signature.
8. Notices *re* change of name from Non-Government Servants and Trade Advertisements are not accepted for publication.
9. Advertisements purporting to be issued under orders of Courts will not be inserted unless signed or attested by a Proctor of the Supreme Court.
10. The authorized Scale of Charges for Notices and Advertisements is as follows from July 16, 1962:—

|   | Rs. c. |
|---|--------|
| One inch or less ... ..                                   | 10 0   |
| Every additional inch or fraction thereof ... ..          | 10 0   |
| One column or $\frac{1}{2}$ page of <i>Gazette</i> ... .. | 110 0  |
| Two columns or one page of <i>Gazette</i> ... ..          | 220 0  |

All fractions of an inch will be charged for at the full inch rate.

11. The "Ceylon Government Gazette" is published every Friday. Day of publication is subject to alteration in any week where Public Holidays intervene.
12. All Notices and Advertisements should reach the Government Printer, Government Press, Colombo, by 3.30 p.m. four working days previous to day of publication—(i.e., normally 3.30 p.m. on Monday).

13. **REVISED SUBSCRIPTION RATES EFFECTIVE FROM AUGUST 1, 1963\*:**—

**Government Gazette (Annual)**

|                               | Local<br>Rs. c. | Foreign<br>Rs. c. |
|-------------------------------|-----------------|-------------------|
| Each Part ... ..              | 27 50           | 40 50             |
| One Section of Part I ... ..  | 17 50           | 23 0              |
| Two Sections of Part I ... .. | 25 0            | 33 0              |

Subscriptions to the "Government Gazette" are booked for periods of not less than six months so as to terminate at the end of a calendar year or half year only.

\*Rates for Single Copies, if available in Stock

|   | Price<br>Cents | Postage<br>(Local)<br>Cents |
|---|----------------|-----------------------------|
| (a) (i) Each part of the <i>Gazette</i> within one week from the date of the <i>Gazette</i> ... ..              | 30             | 20                          |
| (ii) Each part of the <i>Gazette</i> after one week from the date of the <i>Gazette</i> ... ..                  | 60             | 20                          |
| (b) (i) Each Section of Part I of the <i>Gazette</i> within one week from the date of the <i>Gazette</i> ... .. | 15             | 15                          |
| (ii) Each Section of Part I of the <i>Gazette</i> after one week from the date of the <i>Gazette</i> ... ..     | 80             | 15                          |

All remittances should be made in favour of the Superintendent, Government Publications Bureau, P. O. Box 500, Colombo, who is responsible for booking subscriptions and for sale of single copies.